

MONTHLY MOORAGE APPLICATION

Select location:	<input type="checkbox"/> Shilshole Bay Marina	<input type="checkbox"/> Harbor Island Marina	<input type="checkbox"/> Bell Harbor Marina
Select Moorage Type:	<input type="checkbox"/> Wet Moorage	<input type="checkbox"/> Dry Moorage (SBM)	<input type="checkbox"/> Live-aboard (SBM) <input type="checkbox"/> Kayak Storage
Select Term:	<input type="checkbox"/> Monthly Moorage: Starting _____ <input type="checkbox"/> Temporary Moorage: From _____ to _____		

How did you find us? (Check One)	<input type="checkbox"/> Boat Show	<input type="checkbox"/> Friend Referral	<input type="checkbox"/> Referral from another Marina
	<input type="checkbox"/> Broker Referral	<input type="checkbox"/> Internet	<input type="checkbox"/> Other: _____
	<input type="checkbox"/> Former Customer	<input type="checkbox"/> Newspaper or Magazine: _____	

Customer Name:		City:	
Address:		State:	Zip:
Home Phone:	Mobile Phone:	Work Phone:	
E-mail (REQUIRED):			
Vessel Name:		WN or Document Number:	
ELOV*:	Beam**:	Make & Model:	Sail/Power:
Emergency Contact:		Emergency Phone:	
		Emergency Phone:	

* ELOV = Extreme Length of Vessel includes bow sprint, swim step, davits, dinghy, rudder posts, or anything else that adds to the overall length.

** Beam is measured at widest point of vessel.

- 1) **The non-refundable application fee is \$100 for either Shilshole Bay Marina or Harbor Island Marina.** This fee only applies if moorage is not immediately available and your name is placed on a waitlist. This administrative fee is not a deposit and will not be applied towards any of your moorage fees.
- 2) **Applicant agrees to keep the marina office advised of any changes in address and contact information.** When moorage becomes available we will notify you by email and follow up by telephone if there is no response to the emailed offer. If we are unable to reach you, or you fail to accept our offer of moorage in a timely manner, your application fee is forfeit and your name will be removed from the wait list without further notice.
- 3) **Prior to move-in the Port of Seattle requires a signed moorage agreement, proof of ownership, proof of insurance, and the first month's moorage fee.** Upon completion of the moorage agreement and receipt of these items you will be issued key-fobs, a parking permit, and other pertinent information.
- 4) **Only the applicant signing this application will have rights to moorage at a Port of Seattle marina.** The slip for which you have applied will be for the benefit of the below named/signed applicant, his/her spouse/valid domestic partner, and/or minor children.
- 5) This application only applies to the vessel size and characteristics stated above. If you decide to moor a larger or smaller vessel and want a different size slip, you may submit a Change Request for a fee of \$50.00. Please note the waiting times vary for each slip size.
- 6) **Your vessel must fit the assigned slip in order to retain moorage.** It is important that the vessel size listed above remains accurate.
- 7) Permitted watercraft includes vessels being used as a means of transportation, recreational boating, yachting, or commercial fishing which are designed for and capable of navigation on open waters. **Houseboats are not allowed.**
- 8) See appropriate Customer Handbook for complete list of policies. A copy of the current tariff and Marina Regulations, Policies and Procedures are all available at the marina office or online at www.portseattle.org.

By signing this application, I agree to the above conditions.

Signature of Applicant:

Date:

For office use only:

Method of Payment: Cash Check Visa MasterCard

Credit card number: _____ Exp. Date: _____

Processed by: _____ Date: _____ Customer #: _____ Payment ID: _____ Revised 01/18

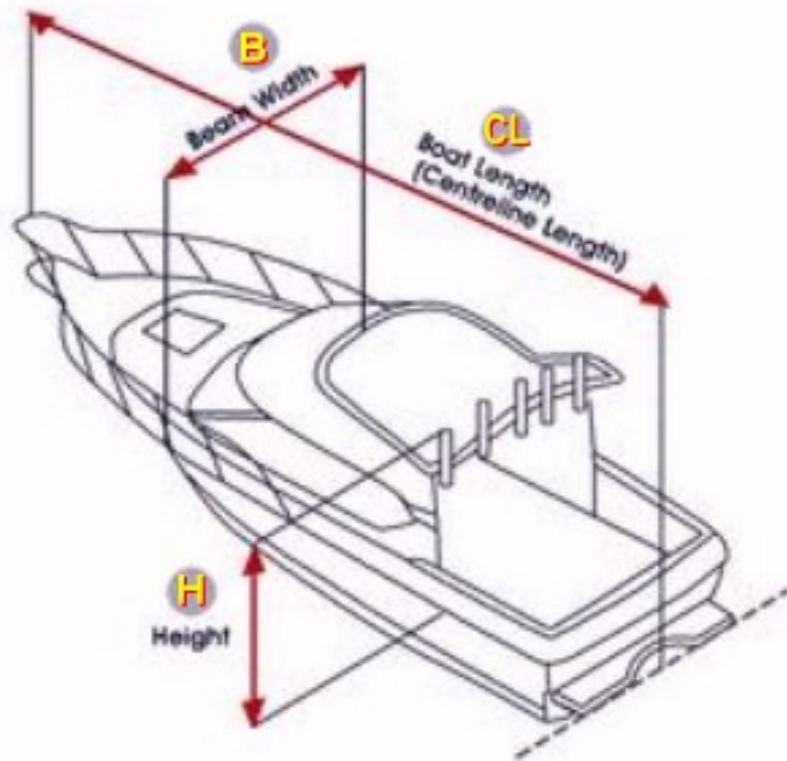
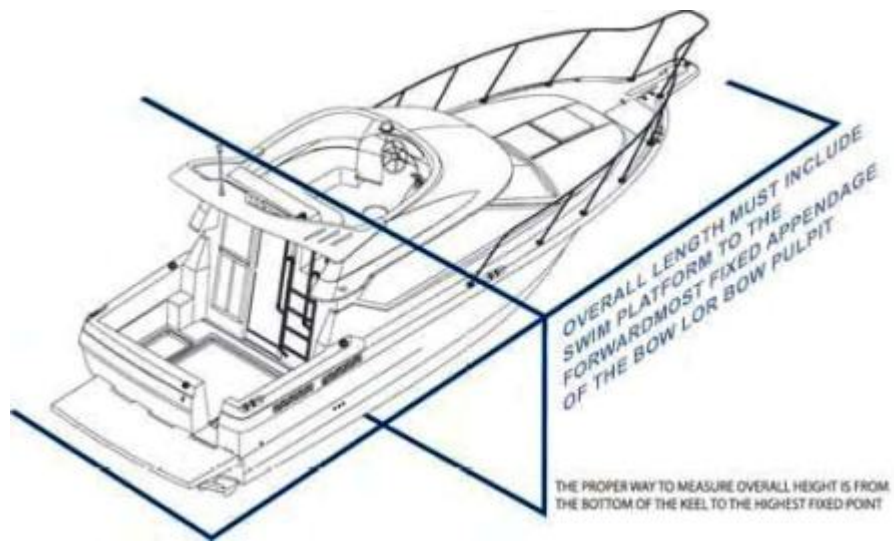

Click here to acknowledge you used these measuring techniques to correctly measure your boat.



New Moorage Application Addendum

With your moorage application, please include:

- **Side-view photos of the vessel to be moored at Shilshole Bay Marina from both the bow and stern**
- **Current State Registration/USCG Documentation**
- **Current proof of minimum \$300,000 liability insurance**

Please initial each item and submit with the necessary items:

_____ I understand that the vessel to be moored at Shilshole Bay Marina must be navigable in open water under its own power as per Moorage Tariff Item 2100-A-21: "Vessels moored in a Port harbor must, at all times, be completely seaworthy, meaning that it is operable and ready for immediate cruising in local waters."

_____ I understand Shilshole Bay Marina does not allow for any overhang from slips and that the extreme length of the vessel (ELOV) to be moored at Shilshole Bay Marina must fit entirely within its slip. I also understand that if my vessel is too large for the slip I am offered I may be forced to forfeit my offer of moorage or my spot on the waitlist.

_____ I have measured the ELOV for the vessel to be moored at Shilshole Bay Marina and have recorded it accurately on my Moorage Application **OR** I acknowledge I will measure the ELOV for the vessel to be moored at Shilshole Bay Marina and will report it accurately to the marina before I may moor a vessel at Shilshole Bay Marina if I have not yet purchased a vessel.

_____ I have submitted side-view photos of the vessel to be moored at Shilshole Bay Marina taken from both the bow and stern with my moorage application **OR** I acknowledge these photos must be provided before I may moor a vessel at Shilshole Bay Marina if I have not yet purchased a vessel.

_____ I have submitted current Washington State registration or U.S. Coast Guard documentation for the vessel to be moored at Shilshole Bay Marina **OR** I acknowledge these documents must be provided before I may moor a vessel at Shilshole Bay Marina if I have not yet purchased a vessel.

_____ I have submitted current proof of the minimum \$300,000 liability insurance for the vessel to be moored at Shilshole Bay Marina **OR** I acknowledge these insurance documents must be provided before I may moor a vessel at Shilshole Bay Marina if I have not yet purchased a vessel.

Signature: _____

Date: _____

To submit application: save the form as a PDF and attach the PDF to an email to sbm@portseattle.org.